

**⚠ WARNING** Indicates a hazard which, if not avoided, could result in serious injury or death.

## GENERAL SAFETY INSTRUCTIONS

### ⚠ WARNING

- Read and follow all instructions carefully.
- Disconnect and lock out power before installation and maintenance. Working on or near energized equipment can result in severe injury.
- Do not operate equipment without guards in place. Exposed equipment can result in severe injury or death.
- Read and understand the information in this section and in this manual completely before installing, operating or maintaining this equipment. Failure to follow this instruction could result in severe injury or death.

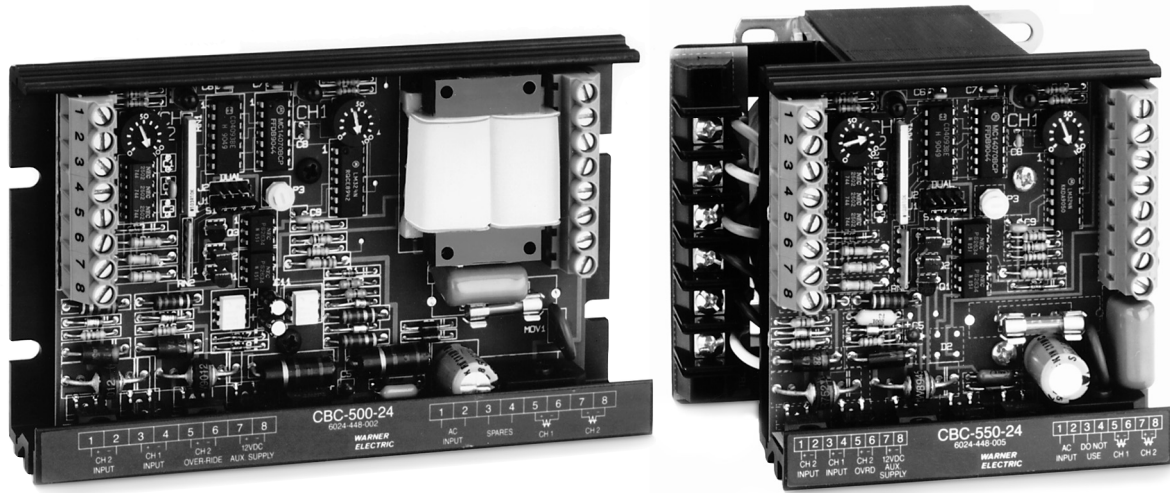

## Contents

1.0 Introduction .....	2
2.0 Specifications .....	2
3.0 Installation .....	3
4.0 Control Adjustment .....	3
5.0 Switching Options .....	4
6.0 Mode Options .....	4
7.0 Dimensional Diagrams .....	5
8.0 System Troubleshooting .....	6
9.0 Declaration of Conformity .....	7
10.0 Mounting Templates .....	8
Warranty .....	9

## 1.0 INTRODUCTION

Warner Electric™ CBC-500 and CBC-550 series clutch/brake controls are compact units designed for operation with Warner Electric 90VDC and 24VDC clutches and brakes, including failsafe units. Dual channel torque adjustment is provided via on-board potentiometers for soft starts and stops as well as accurate release points for failsafe designs. These controls can operate with each channel either in dual or single mode. Dual or single mode is controlled via an on board jumper for use in a variety of applications. A transformer is provided on the CBC-550 series controls, extending the input AC voltage range. Four models are available:

<b>CBC-500-90</b>	120 VAC input
<b>CBC-500-24</b>	24-30 VAC or VDC input
<b>CBC-550-90</b>	120/220/240/380/480 VAC input
<b>CBC-550-24</b>	120/220/240/380/480 VAC input

Three optically isolated inputs provide full flexibility in interfacing customer supplied switching schemes. Internal circuitry provides suppression of transients during decay of the magnetic field to assure rapid cycle rates. Two LED indicators are provided on the control board for channel 1 and channel 2 indication.



## 2.0 SPECIFICATIONS

### 2.1 Input

<b>CBC-500-90</b>	120 VAC ± 10%, 50/60 Hz, 1 phase, 250 VA max.
<b>CBC-500-24</b>	24-30 VAC, 50/60 Hz, 1 phase; or 24-30 VDC, 250 VA max.
<b>CBC-550-90</b>	120/220/240/380/480 VAC ± 10%, 50/60 Hz, 1 phase, 250 VA max.
<b>CBC-550-24</b>	120/220/240/380/480 VAC ± 10%, 50/60 Hz, 1 phase, 250 VA max.

### 2.2 Output

<b>CBC-500-90</b>	0-90 VDC full-wave rectified nominal, 1.0 amp per channel max., 2.0 amps total
<b>CBC-500-24</b>	0-24 VDC full-wave rectified nominal, 5.0 amps per channel max., 5.0 amps total
<b>CBC-550-90</b>	0-90 VDC full-wave rectified nominal, 1.0 amp per channel max., 1.2 amps total
<b>CBC-550-24</b>	0-24 VDC full-wave rectified nominal, 4.0 amps per channel max., 4.0 amps total

### 2.3 Circuit Positioning (Fusing)

<b>CBC-500-90</b>	0-90 VDC full-wave rectified nominal, 1.0 amp per channel max., 2.0 amps total
<b>CBC-500-24</b>	0-24 VDC full-wave rectified nominal, 5.0 amps per channel max., 5.0 amps total
<b>CBC-550-90</b>	0-90 VDC full-wave rectified nominal, 1.0 amp per channel max., 1.2 amps total
<b>CBC-550-24</b>	0-24 VDC full-wave rectified nominal, 4.0 amps per channel max., 4.0 amps total

### 2.4 Switching Inputs: (external to control, supplied by customer)

<b>Three optically isolated, 10-30 VDC</b>	Channel 1 Input (adjustable voltage applied to channel 1)
	Channel 2 Input (adjustable voltage applied to channel 2)
	Channel 2 Override Input (full voltage applied to channel 1)
	Maximum off-state leakage < 1 mA

### 2.5 Adjustments

- Channel 1 Voltage (via potentiometer)
- Channel 2 Voltage (via potentiometer)
- Jumper (selects simultaneous or alternate mode)
- Frequency Adjustment: 60-400 Hz (via potentiometer)

### 2.6 Ambient Temperature

-20° to 122°F (-29° to 50°C)

### 2.7 Auxiliary Supply

12 VDC, 250 mA maximum

### 2.8 Enclosure

Optional NEMA 13 enclosure available

### 3.0 INSTALLATION

**WARNING!** The voltages present in this control can cause serious injury (even death). When installing this control or any electrical equipment, make certain that the input power is off. Do not apply power to this control until it is securely mounted and completely wired in accordance with local codes and all installation work, including cleanup, has been completed.

#### 3.1 Connection Diagrams

##### CBC-550 Series

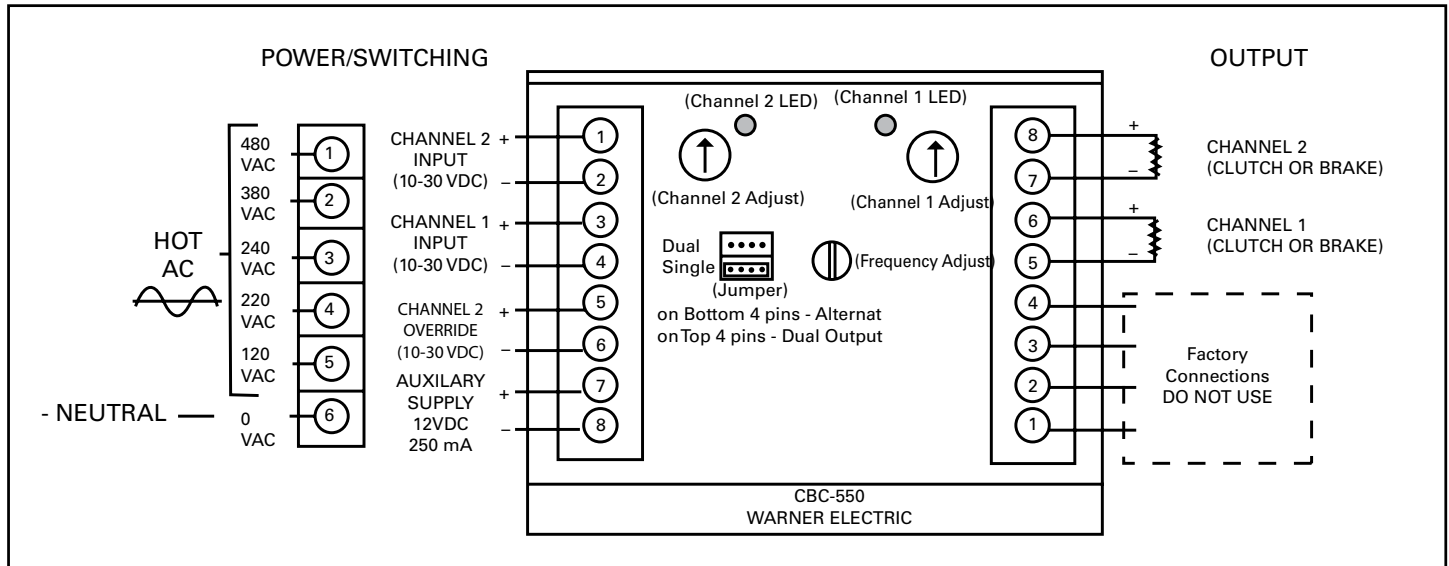

##### CBC-550 Series

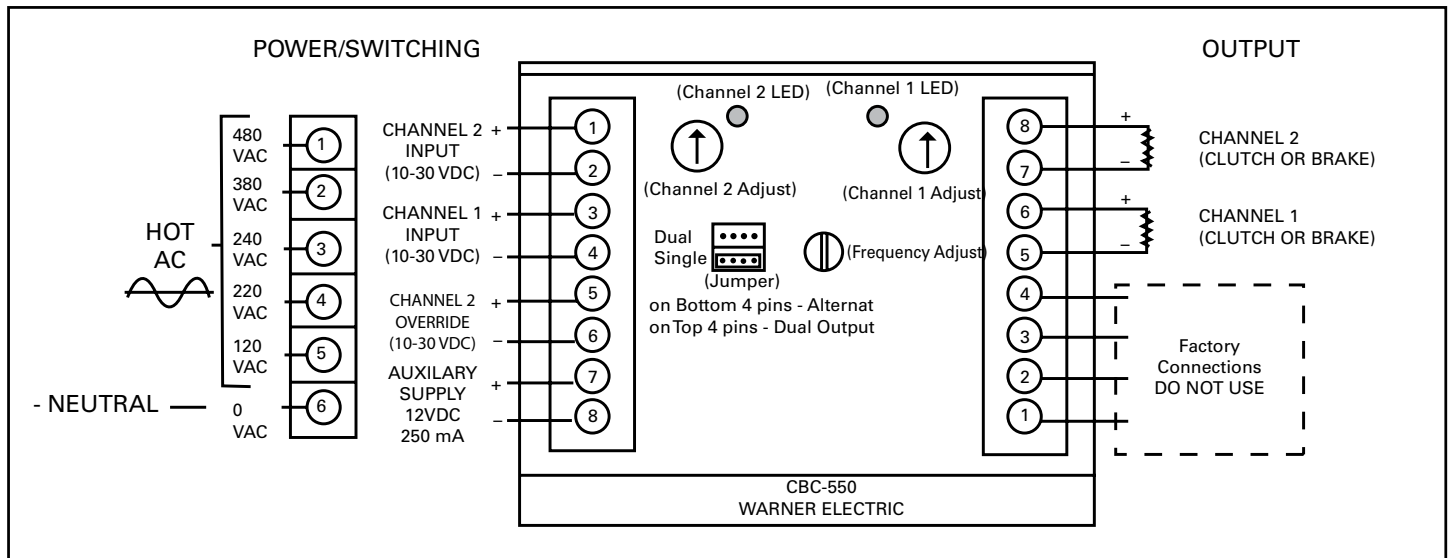

### 4.0 CONTROL ADJUSTMENTS

**Channel 1 and Channel 2 Torque Adjustment:** Provides adjustment of 0 to full rated voltage.

**Jumper:** Allows operation of alternate or simultaneous mode of operation. In the single mode, Channel 1 and Channel 2 function in an alternate mode. In the dual mode Channel 1 and Channel 2 function simultaneously. This mode will be employed in applications with a clutch and a failsafe brake. The control is shipped with the jumper placed for the single mode of operation. To change to dual mode, carefully remove the jumper and reinsert it on the dual side of the terminal block.

**Frequency Adjustment:** Provides adjustment of 60 to 400 Hz. This adjustment is simply to reduce the clutch/brake "hum" associated with machine frequencies.

## 5.0 SWITCHING OPTIONS

### Option 1: External Power Supply

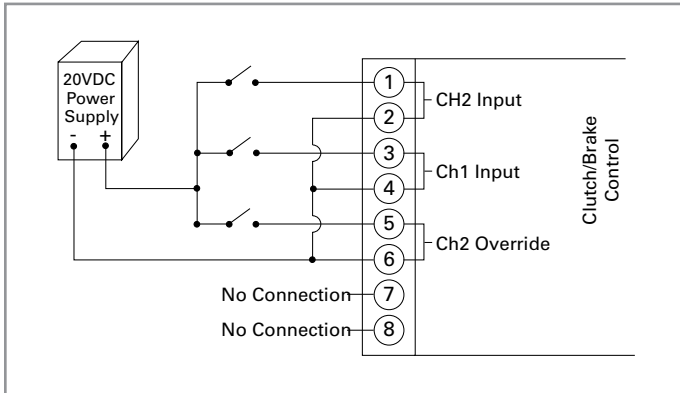

### Option 2: Internal Power Supply

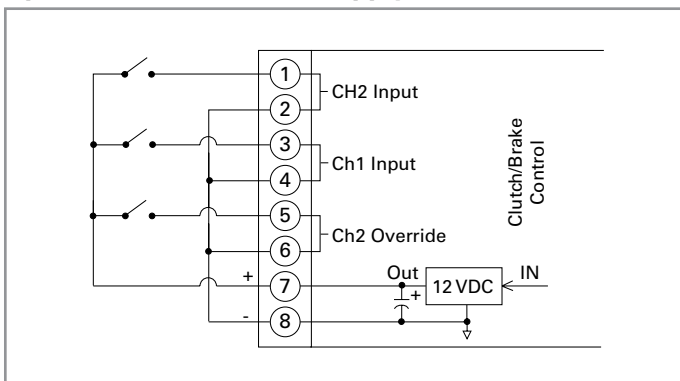

### Option 3: PLC

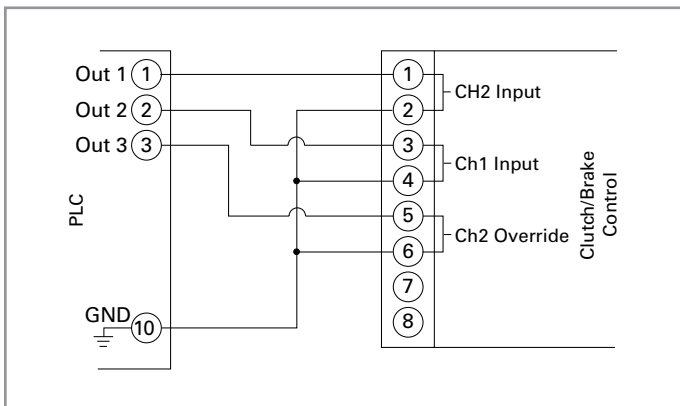

**Note 1:** The minimum “on time” or “close time” of each switch is 10m seconds.

**Note 2:** The switches in the above schematics can be replaced with any kind of dry contact switches; or any kind of relays. Examples: mechanical relays, momentary contact switches, toggle switches, transistors, mosfets, solid state relays, PLC outputs, etc.

**Note 3:** The logic inputs of the clutch/brake control are optically isolated

## 6.0 MODE OPTIONS

### 6.1 Single Mode

Ch1	Ch2	Ch2 Ove	Ch1 output	Ch2 output
0	0	0	No change	No change
0	0	1	On at full torque	Off
0	1	0	Off	On at full torque
0	1	1	On at full torque	Off
1	0	0	On at adjusted torque	Off
1	0	1	Full torque	Off
1	1	0	On at adjusted torque	Off
1	1	1	Full torque	Off

### 6.2 Dual Mode

Ch1	Ch2	Ch2 Ove	Ch1 output	Ch2 output
0	0	0	No change	No change
0	0	1	Off	Off
0	1	0	On at adjusted torque	On at adjusted torque
0	1	1	Off	Off
1	0	0	Off	Off
1	0	1	Off	Off
1	1	0	Off	Off
1	1	1	Off	Off

**Note 1:** In single mode, when power is applied to the control, Ch1 comes on at adjusted voltage until a logic input changes the output voltages.

**Note 2:** In single mode the control can not “turn off” both channels at the same time; or “turn on” both channels at the same time.

**Note 3:** When voltage is applied to “Ch2 override,” Ch2 and Ch1 logic inputs are ignored and the outputs are changed to:

Ch1 = full torque and Ch2 = off.

When power is removed from “Ch2 override,” the control reads the logic inputs and changes the voltage output accordingly. If no power is applied to the logic inputs when power is removed from Ch2 override, then the output voltages remain at:

Ch 1 = full torque for Ch 1 and Ch2 = Off  
Example:

## 7.0 DIMENSIONAL DIAGRAMS

### CBC-500

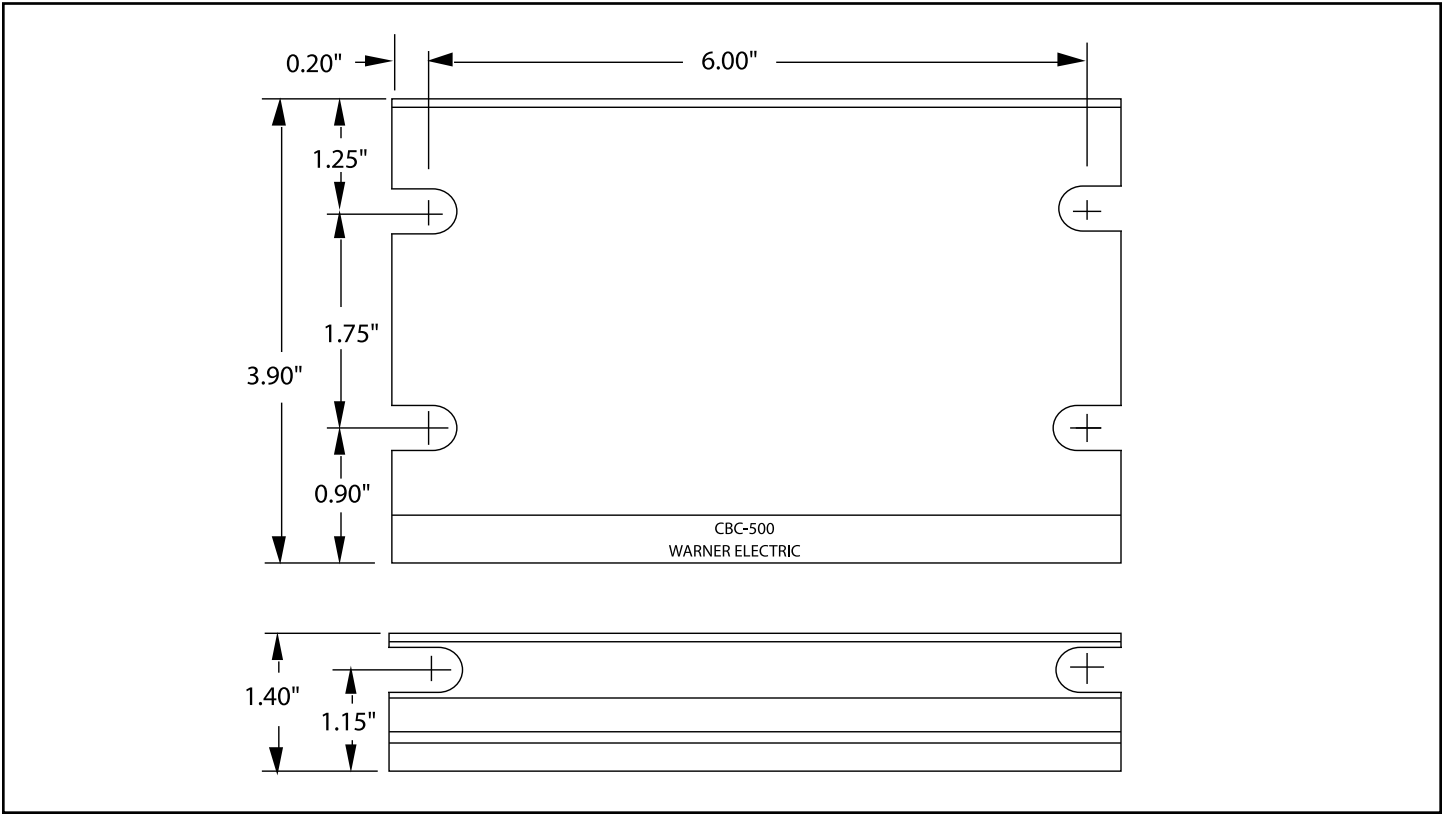

This control may be mounted on its base (two mounting slots) or on its back (four mounting slots).

**Note:** All dimensions nominal.

### CBC-550

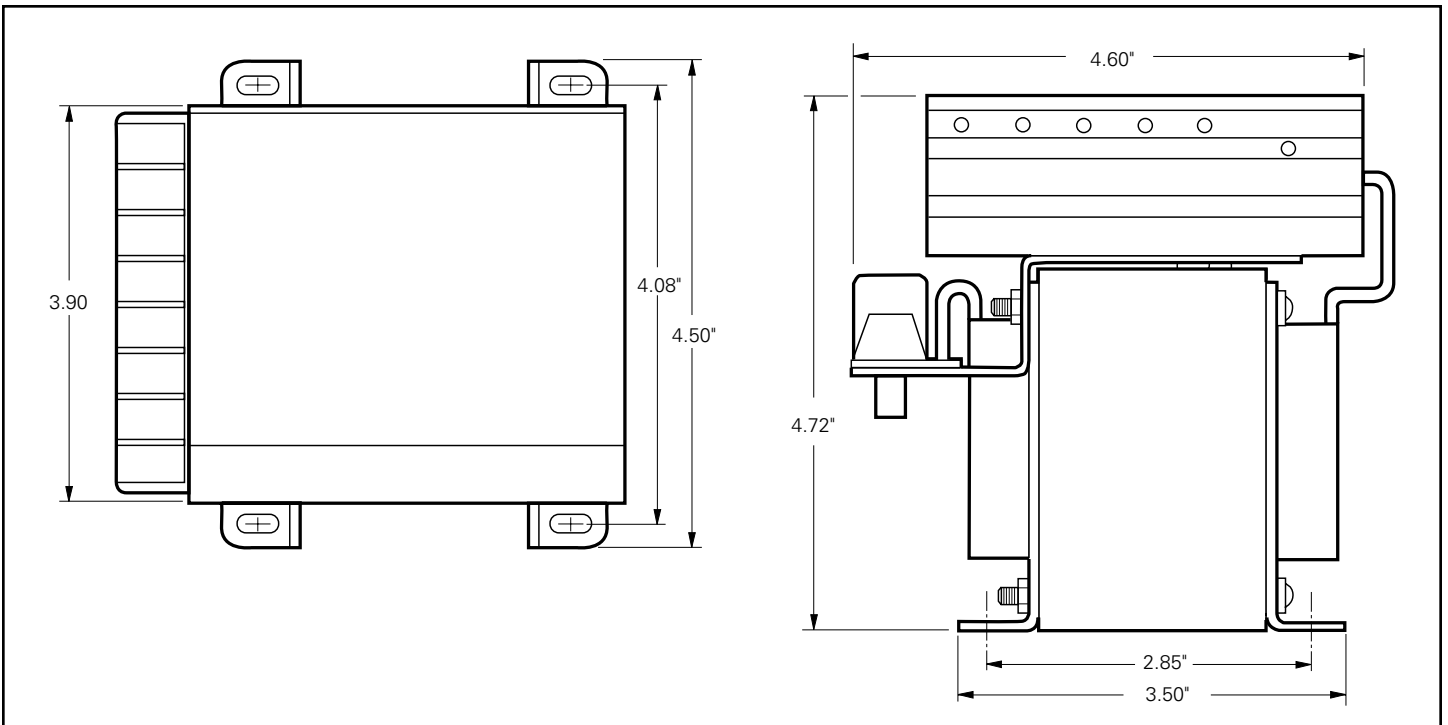

## 8.0 SYSTEM TROUBLESHOOTING

The chart below will be helpful when attempting to isolate problems which may occur in the control system. It will also prove helpful when encountering problems during initial system start-up.

<b>Symptom A: No output on either channel upon power-up.</b>	
<b>Probable Cause</b>	<b>Solution</b>
Improper wiring	Check wiring and correct if necessary.
No power available	Check that AC power is available to control.
Blown fuse	See Fuse keeps blowing, Symptom C.

<b>Symptom B: Channel 2 activates upon power-up.</b>	
<b>Probable Cause</b>	<b>Solution</b>
Improper wiring	Check wiring and correct if necessary.
Faulty input switching circuit	Check that input switching network is providing proper signal.

<b>Symptom C: Fuse keeps blowing.</b>	
<b>Probable Cause</b>	<b>Solution</b>
Improper wiring	Check wiring and replace fuse.
Shorted brake/clutch coil	Check coil resistance and replace if necessary.
Fuse too small	Replace with proper fuse.
Improper AC line voltage	Check line voltage and correct if necessary.
Improper magnet voltage	Check magnet voltage rating and replace with correct magnet if necessary.

<b>Symptom D: Magnets do not appear to have enough torque.</b>	
<b>Probable Cause</b>	<b>Solution</b>
Magnets incorrectly sized	Verify sizing by repeating the selection process.

<b>Symptom E: Outputs don't switch; Inputs don't switch.</b>	
<b>Probable Cause</b>	<b>Solution</b>
Incorrectly wired inputs	Check wiring and correct if necessary.
Faulty switching device	Check for proper operation and replace if defective.
Faulty control	Replace control.

### Reorder Information

<b>Model</b>	<b>Part No.</b>
CBC-500-90	6024-448-003
CBC-500-24	6024-448-002
CBC-550-90	6024-448-006
CBC-550-24	6024-448-005
CBC-500 Series Enclosure	6042-101-004
CBC-550 Series Enclosure	6006-101-007

## 9.0 DECLARATION OF CONFORMITY

WE: **WARNER ELECTRIC**  
449 Gardner Street  
South Beloit, IL 61080

declare under our sole responsibility that the products of the family  
**CBC 500-90 & CBC 500-24**  
**CBC 550-90 & CBC 550-24**

are exclusively designed for incorporation in another machine. The operation of the product is submitted to the conformity of the complete equipment, following the provisions of the directive **89/392/EEC**.

The conformity of the above specified products with the provisions of the Directive **72/23/EEC** is supported by the full respect of the standards **EN 61010-1**.

If the mounting and connecting instructions of the installation's manual have been respected, this product will be conform to the standards **EN50081-1** and **EN50082-1** relating to the EMC directive **89/336/EEC**.

South Beloit, IL 61080  
VP and General Manager: S. O.



**⚠ WARNING** To avoid injury, always make certain all power is off before attempting to install or repair this control.

**DO NOT TOUCH THE BOARD IF POWER IS APPLIED.**

### Mounting and Connecting Instructions

related to the EMC-directive 89/336/EEC

#### For Clutch and Brake Control

1. The control must be mounted in a closed metal cabinet.
2. The power connection between control and clutch/brake must be MADE using shield cable.
3. The control connection must utilize shielded cables.
4. The shield of the cables must be grounded at both ends.
5. Power connections and control connection must be placed in separate canals.

## KONFORMITÄTSERKLÄRUNG

Wir: **WARNER ELECTRIC**  
449 Gardner Street  
South Beloit, IL 61080

erkären in alleiniger Verantwortung, daß die Produkte der Familie  
**CBC 500-90 & CBC 500-24**  
**CBC 550-90 & CBC 550-24**

ausschließlich zum Einbau in eine andere Maschine bestimmt sind. Die Inbetriebnahme ist solange untersagt, bis die Konformität des Endproduktes mit der Richtlinie **89/392/EWG** gegeben ist.

Die Übereinstimmung des bezeichneten Produktes mit den Vorschriften der Richtlinie **72/23/EWG** wird nachgewiesen durch die Einhaltung der Normen **EN 61010-1**.

Sofern die Montage-Anweisungen der Bedienungsanleitung eingehalten wurden, ist dieses Produkt knoform zu **EN50081-1** und **EN50082-1** und die EMV somit gewährleistet - Richtlinie **89/336/EWG**.

South Beloit, IL 61080  
VP and General Manager: S. O.



**⚠ WARUNG:** Vor Einbau oder Wartung des Gerätes unbedingt die Stromversorgung unterbrechen um Verletzungen zu vermeiden.

**KARTE BEI EINGESCHALTETER STROMVERSORGUNG NICHT BERÜHREN.**

### MONTAGE UND KABELVERBINDUNGEN ANWEISUNGEN

bezogen zu den EMW Richtlinie 89/336/EWG

#### FÜR STEUERGERÄTE KUPPLUNGEN UND BREMSEN

1. Das Gerät muß in einem geschlossenen metallschrank eingebaut werden.
2. Leistungsverbindungen Steuergeräte/Kupplungen - Bremsen mit abgeschim Kabel durchfuhren.
3. Steuerleitungen, Ein-und Ausgänge mittels abgeschimten Kabeln durchfuhren.
4. Abschirmung an beiden Enden des Kabels erden.
5. Leistungs-und Steuerverbindungen in separate Kabelkanäle durchziehen.

## DECLARACION DE CONFORMIDAD

Nosotros: **WARNER ELECTRIC**  
449 Gardner Street  
South Beloit, IL 61080

declaramos bajo nuestra propia responsabilidad que los productos de la familia

**CBC 500-90 & CBC 500-24**  
**CBC 550-90 & CBC 550-24**

son diseñados exclusivamente para incorporarse en otra maquina. El funcionamiento de este producto esta sujeto al cumplimiento de todo el equipo usado en la maquina, con los lineamientos de la norma **89/392/EEC**.

El cumplimiento de los lineamientos de la norma **72/23/EEC** con los productos mencionados anteriormente, se basa y respeta los estandares **EN 61010-1**.

Si las instrucciones de montaje e instalacion electrica del instructivo son respetadas, este producto cumplirá con los estandares **EN50081-1** y **EN50082-1** que se relacionan con la norma **89/336/EEC**.

South Beloit, IL 61080  
VP and General Manager: S. O.



**⚠ ADVERTENCIA:** Para evitar cualquier daño personal, antes de intentar instalar o reparar este control, siempre asegurese que todas las fuentes de poder esten apagadas.

**NO TOQUE EL CIRCUITO ELECTRICO SI LA FUENTE DE PODER ESTA ENCEDIDA.**

### INSTRUCCIONES DE MONTAJE Y CONEXIONES ELECTRICAS

en relación a la norma de EMC 89/336/EEC

#### PARA CONTROLES DE CLUTCHES Y FRENOS

1. El control debe de instalarse adentro de una caja metalica.
2. Las conexiones electricas entre el control y el clutch/freno DEBEN hacerse con cable blindado.
3. Las conexiones de bajo voltaje en el control deben utilizar cables blindados.
4. El blindaje de los cables debe de aterrizarse en ambos lados.
5. Las conexiones entre la fuente de poder, y las conexiones de bajo voltaje deben de hacerse en diferentes cables.

## DÉCLARATION DE CONFORMITÉ

Nous: **WARNER ELECTRIC**  
449 Gardner Street  
South Beloit, IL 61080

déclarons sous notre seule responsabilité que les produits de la famille  
**CBC 500-90 & CBC 500-24**  
**CBC 550-90 & CBC 550-24**

son uniquement destinés à l'intégration dans une machine. La mise en service de ces produits est subséquente à l'homologation de l'ensemble de l'équipement, conformément à la directive **89/392/CEE**.

La conformité des produits spécifiés ci-dessus avec les exigences de la directive **72/23/CEE** est supportée par le respect des normes **EN 61010-1**.

Si les instructions de montage et de câblage du manuel sont respectées, ce produit est conforme aux normes **EN50081-1** et **EN50082-1** directive **89/336/CEE** relative à la CEM.

South Beloit, IL 61080  
VP and General Manager: S. O.



**⚠ ADVERTISSEMENT:** Afin d'éviter des blessures, s'assurer que toute puissance soit coupée avant installation ou intervention sur ces équipements.

**NE PAS TOUCHER LE CIRCUIT ÉLECTRONIQUE, SI LA PUISSANCE EST APPLIQUÉE.**

### INSTRUCTIONS D'INSTALLATION ET DE CABLAGE

relatives à la CEM, directive 89/336/CEE

#### DES CONTROLES POUR EMBRAYAGES ET FREINS

1. L' appareil doit être monté dans une armoire métallique close.
2. Liaison de puissance entre contrôle et embrayage/frein par câble blindé.
3. Raccordements de consigne, entrées et sorties par câbles blindés.
4. Les blindages sont reliés à la terre aux deux extrémités du câble.
5. Les câbles de commande et les câbles de puissance ne seront pas placés dans le même caniveau.

## 10.0 MOUNTING TEMPLATES

### CBC-500

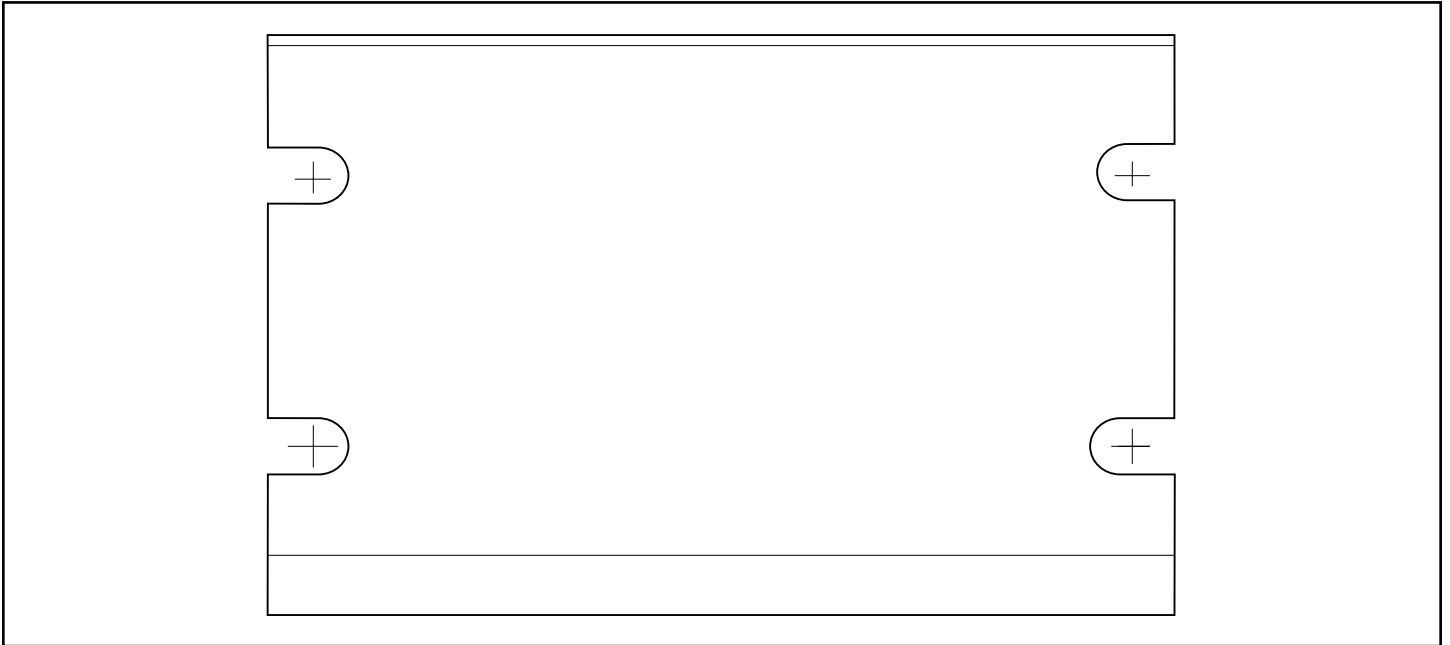

### CBC-550

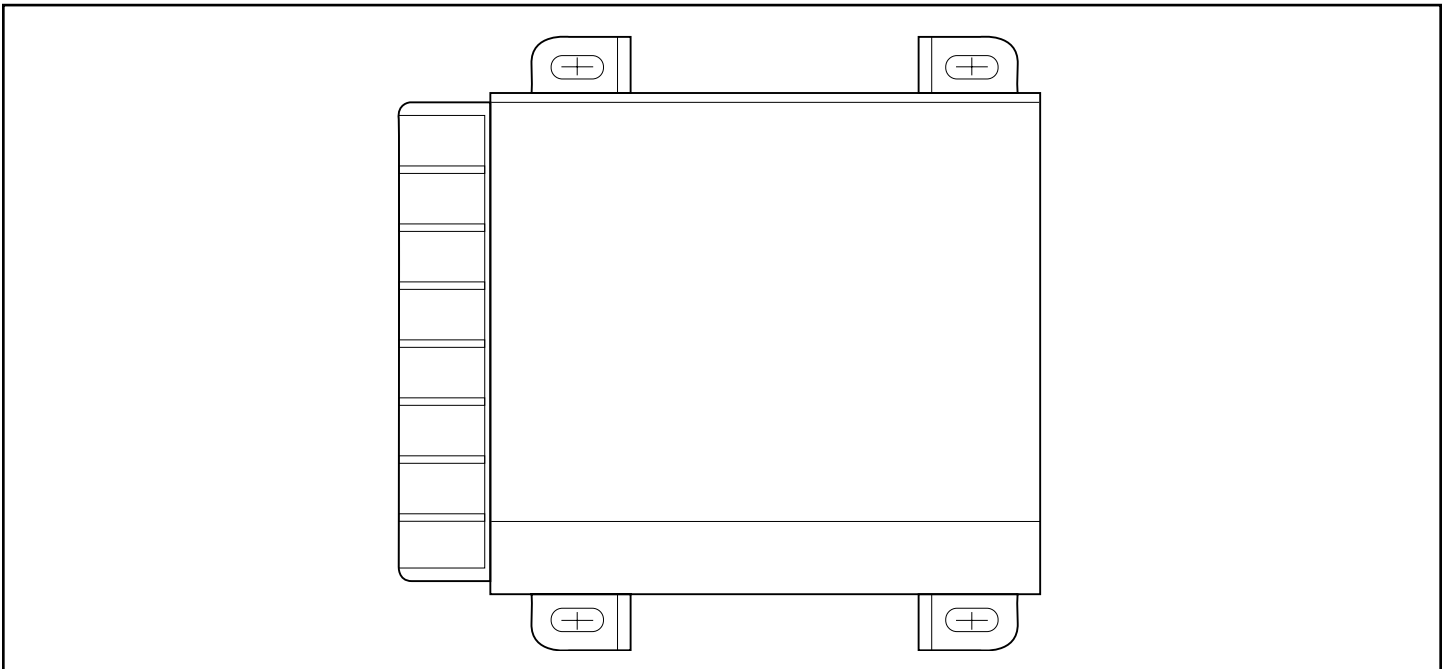



## Warranty

Warner Electric LLC warrants that it will repair or replace (whichever it deems advisable) any product manufactured and sold by it which proves to be defective in material or workmanship within a period of one (1) year from the date of original purchase for consumer, commercial or industrial use.

This warranty extends only to the original purchaser and is not transferable or assignable without Warner Electric LLC's prior consent.

Warranty service can be obtained in the U.S.A. by returning any defective product, transportation charges prepaid, to the appropriate Warner Electric LLC factory. Additional warranty information may be obtained by writing the Customer Satisfaction Department, Warner Electric LLC, 449 Gardner Street, South Beloit, Illinois 61080, or by calling 815-389-3771.

A purchase receipt or other proof of original purchase will be required before warranty service is rendered. If found defective under the terms of this warranty, repair or replacement will be made, without charge, together with a refund for transportation costs. If found not to be defective, you will be notified and, with your consent, the item will be repaired or replaced and returned to you at your expense.

This warranty covers normal use and does not cover damage or defect which results from alteration, accident, neglect, or improper installation, operation, or maintenance.

Some states do not allow limitation on how long an implied warranty lasts, so the above limitation may not apply to you.

Warner Electric LLC's obligation under this warranty is limited to the repair or replacement of the defective product and in no event shall Warner Electric LLC be liable for consequential, indirect, or incidental damages of any kind incurred by reason of the manufacture, sale or use of any defective product. Warner Electric LLC neither assumes nor authorizes any other person to give any other warranty or to assume any other obligation or liability on its behalf.

WITH RESPECT TO CONSUMER USE OF THE PRODUCT, ANY IMPLIED WARRANTIES WHICH THE CONSUMER MAY HAVE ARE LIMITED IN DURATION TO ONE YEAR FROM THE DATE OF ORIGINAL CONSUMER PURCHASE. WITH RESPECT TO COMMERCIAL AND INDUSTRIAL USES OF THE PRODUCT, THE FOREGOING WARRANTY IS IN LIEU OF AND EXCLUDES ALL OTHER WARRANTIES, WHETHER EXPRESSED OR IMPLIED BY OPERATION OF LAW OR OTHERWISE, INCLUDING, BUT NOT LIMITED TO, ANY IMPLIED WARRANTIES OF MERCHANTABILITY OR FITNESS.

Some states do not allow the exclusion or limitation of incidental or consequential damages, so the above limitation or exclusion may not apply to you. This warranty gives you specific legal rights and you may also have other rights which vary from state to state.

### **Changes in Dimensions and Specifications**

All dimensions and specifications shown in Warner Electric catalogs are subject to change without notice. Weights do not include weight of boxing for shipment. Certified prints will be furnished without charge on request to Warner Electric.